



Pontiac-Oakland
Club International
Incorporated (POCI)

Custom Safari Chapter

Winter 2001 - 2002
Volume 3, Number 4

In This Issue.....

President's Garage.....

Editor's Notes.....

Good Guys Article.....

Member of the Quarter.....

Pontiac Literature.....

Vintage Article.....

Service Information.....

Chapter Membership.....

Safari Search.....



Dues Are Due.

If you have a RED "X" on your envelope,
please send them in immediately, otherwise we
may do this to your favorite Safari!



From the President's Garage

By Robin Clark

Hello Safari kids,

Happy New Year to everyone. 2001 is now history, although my boss still seems to think I'm out in space somewhere, but that's another story. 2002 looks to be like a promising year for both our chapter and P.O.C.I.

The GMC issue should be settled soon. I hope everybody participated in the voting and will be happy with the outcome. I know P.O.C.I. has worked hard on this whole issue. The Custom Safari Chapter, seems to be holding our own in membership, hovering around the 50 mark. If anyone has any ideas on promoting our chapter, please send them in, we are more than glad to hear from you. And a big thanks to everyone for hanging on.

On the car front, as I mentioned in the past, one of my left leaf springs was broken, making the car sag in the left rear, but on my last big outing, one of the springs on the right broke. Don't feel sorry for me. This is a good thing, because now I have an even sag in the rear of the car. Yeah I know, as Tom Young would tell me, fix it. Easier said than done though. Since the weather has been very nice here, work has been very busy for me. The recession has not hit in the concrete business in this area, not yet anyway.

In regards to the upcoming POCI convention, it sounds like Bill Fortune and his troops are putting together a real nice show. I hope a lot of you are planning on going. I'm going to give it my best to be there, it's been a longtime since I've been to that area of the country. It will be nice to see a lot of Safari friends. And don't forget to buy Kodak film for all of your convention picture taking!

May the Safari be with you!

Robin



Behind the Wheel in the Editor's Seat

By Rich Pye

This has been one crazy winter. Since the last newsletter I think I have become a major shareholder in the medical industry. I have had elective surgery and a broken rib. My wife had LASIK surgery that went awry, with twice a week follow-up doctor visits. All three kids have had assorted ear infections, strep throat and the flu. My youngest was hospitalized with pneumonia for three days. Needless to say it has been a trying time.

I haven't done anything with my Safari except move it from the garage to the barn. I am still chasing down a shaking problem at around 55 miles per hour. My buddy has been taking the tires, one at a time to the shop, and both spin balancing and bubble balancing them. We have one more to go and with spring just around the corner, I hope to get it out in a month or so and test drive it.

Winter in Brockport has been fairly mild. While Buffalo, which is 45 miles west of me, got 7 feet of snow between Christmas and New Year's, we only got about 6 inches. I have to admit I laughed my butt off watching the radar on weatherbug.com as the snow front went back and forth over Buffalo for what seemed to be seven days straight. Every time I thought it was heading this way, it retreated and pounded Buffalo again. My sympathy goes out to chapter members Ray and Heidi Kirshner who live in that area. I have only had to plow the driveway twice all year, and haven't even been able to take the kids sledding, (not that sledding with broken ribs would be a whole lot of fun!).

In this issue you'll find a renewal form to fill out and send in with your dues, which are due (\$18). I have also added a section that I would like to become a regular part of the newsletter. It's the Safari Member of the Quarter page. It includes things about you that other members would like to know. Since I didn't want to include a blank page for this issue, I answered the questions for myself. Please take the opportunity to fill out the categories I listed on that page and send the information in along with your dues payment or email it to me directly. Include a picture of your Safari if you can. Also feature articles are always welcome.

Thanks to Gary Parker for his submission to this newsletter. It is a great story of helping your fellow man or woman. I am sure we would all hope to have the same help and would reciprocate the same way. Also please welcome new members David and Mary Jean White from Connecticut. The Whites have a 1956 Custom Safari and a 1931 Pontiac. This makes our third "White" in the chapter and the second from Connecticut.

A sneak preview to the convention in West Virginia hosted by our own Bill Fortune. We are planning to schedule a Custom Safari Chapter breakfast cruise at the Cross Lanes Cracker Barrel, (approx. 9 miles from host Marriott I-64 West -Exit 45), at 9:00 A.M. Thursday, July 11. Although I won't have my Safari, I plan on riding shotgun in my 1994 Chevy Conversion Van! Please join us for this event.

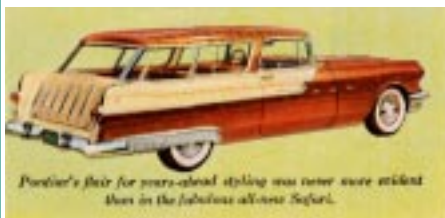

Until next issue, stay healthy, (I know I am going to try), think Spring and get ready to dust off those Safaris!!

Rich

Good Guys Are Out There

By Gary Parker

I don't know if the following is worthy of the "Safari News" and this is "old" news, however, I was reflecting on the events of 9/11 (as I am sure we have all done many times since that infamous date). President Bush rightfully refers to the perpetrators as the "evil doers" and while they are on our minds each and every day, I was reminded of the "good doers" that I encountered as I drove my "fresh" '55 Safari to Grand Rapids for the 2000 POCI convention.

First, a little background information. While reassembling my engine in the final stages of a rebuild, I neglected to use self-locking rocker arm nuts as it "clearly" states in my Pontiac shop manual page 6-45! Since the rebuild, I had only driven my car approximately 20 miles to and from the garage for a NYS inspection prior to the trip to Grand Rapids. Not the smartest thing that I have done since I have owned the Safari. During that short trip, the car purred like a kitten and I must admit, I was feeling pretty good about my shade-tree mechanic abilities.

My itinerary was to drive from Spencerport, NY through Canada to Grand Rapids. Not more than an hour into my trip, I heard the tell tale sound of a "clicking" lifter. At that time, I was disappointed that the formerly purring engine was now making some unwanted noises though I told myself that it was simply part of the breaking in process. After I had crossed the border into Canada, the noise was getting worse and I decided to pull off to the side of the road under an overpass so that I could work in the shade. At this time, I was traveling on the QEW. For those of us who have had the privilege of driving on the QEW, you know that everyone drives very fast and at least 50% of the traffic is made up of tractor-trailers causing a substantial draft as they pass by.

Fortunately, I had packed a full compliment of tools and I commenced to remove the valve cover from the left side of the engine. Sure enough, the rocker arm nuts had loosened and two of the rocker arms had moved out of position. I tightened them and proceeded to work on the right side. As I removed the second valve cover a gentleman pulled over in a pickup truck and offered assistance. Turns out that he was a truck fleet maintenance mechanic and suggested that I try lock washers in an attempt to prevent the rocker arm nuts from loosening. When he opened the back of his truck I was astonished. He had a better assortment of lock washers in his arsenal of parts than a well-stocked hardware store. He gave me as many washers as I thought I needed. After I thanked him profusely and offered to pay him, he simply said, "no thanks, I am glad I could be of help and good luck."

Before I could get the washers in place a second gentleman pulled over and offered to help. Turns out he was a car buff as well. I explained the problem to him and he agreed that the temporary repair was a reasonable roadside remedy. I told him where I was headed and he stated that my route would take me very close to his home. He gave me his address, telephone number and stated that if I had any further problems, I could stop at his house, use his driveway (obviously a better place to make repairs than the shoulder of the QEW) and his tools. I told him that I would most certainly take him up on his generous offer if necessary. I thanked him and he was on his way as was I.

Good Guys continued

After traveling a number of miles, the car started sounding and acting sick again so I pulled off the highway at the first available exit. I found myself on a rural road and pulled off onto the shoulder to begin the procedure of tightening the rocker arm nuts once again. Within five minutes of lifting the hood, a gentleman approached from his home just across the street from where I had parked and asked if he could help. I described the problem to him and told him that I thought I could make the repair, however, I was fresh out of lock washers (I know, I should have installed lock washers on all of the rocker arm studs the first time, once again, wishful thinking). Believe it or not, this gentleman was also a car (truck) buff and offered to provide the necessary lock washers. Of course I asked to see his pickup truck. He allowed me to paw through his stash of nuts, bolts etc. and take whatever I needed to complete the job. I thanked him and offered to pay for the parts that he had provided. He declined and simply said “if there is anything else I can do please ask and good luck.”

By the time I reached Grand Rapids (approximately 11:00 P.M.) the car was running very poorly due to the improper torque applied to the rocker arm nuts, as a result of my hasty road side repairs. The tech inspection was scheduled for the next day and I knew that I could not present the Safari the way it was running. I scoured the yellow pages for local Pontiac/GM dealerships in the area. I began calling at 7:00 A.M. the next morning. I explained that I was attending the National POCI Convention and was desperately in need of immediate service. The manager agreed to help me as soon as I could get the Safari to their garage. Fortunately, the technician assigned to my car had rebuilt several classic car engines. It was immediately obvious that he knew what he was doing. They even allowed me to work along side the mechanic to expedite the rocker arm adjustment and installation of lock nuts to prevent a recurrence of the existing problem. Needless to say, the car got a lot of attention from onlookers and all involved at the dealership stated that working on a classic car was a pleasant change. Once again, the Safari was purring like a kitten and I was first in line for the afternoon tech inspection.

The moral of this not so short story is that the “good doers” make up the vast majority of our population and it is especially evident among car enthusiasts.



Gary Parker

Gary Parker's '55 Safari at the 2000 POCI Convention in Grand Rapids. By the way we hope the ride home was less eventful!

Safari Member of the Quarter

Your Name: Rich Pye

Spouse's name: Paige

Child(ren)'s name(s) and age(s): Mackenzie, 5; Madison, 3; Matthew, 22 mos.

Safari(s) Owned: (3) 1955 Safaris, one runs, one needs restoration, one's parted out

When/Where did you acquire your first Safari? 1987, Williamson, NY.

What was your first car? 1974 Dodge Dart Swinger

What was your first Pontiac? 1977 Bonneville Brougham

Reason for "collecting" Safaris: Rarity of model and Indian heritage

Reason for joining the Custom Safari Chapter: Share stories and learn from other members

Favorite Safari Accessory owned: Remington Auto-Home 12V Electric Razor

Most wanted Safari Accessory: Illuminated Compass

Do you have "other" Pontiacs? If so, list model and year: 1955 Chieftain, 1969 GTO, 1998 Trans Sport

What are your favorite non-Pontiac hobbies? Camping, do-it-yourself stuff

Least favorite car task: Exhaust work

Most favorite car task: Collecting parts and driving

Best thing about being a Pontiac Custom Safari Owner: Everyone thinks the car is cool!

Favorite non-Safari car: 1969 GTO

Favorite car-related web site: classicalpontiac.com

Favorite parts vendor: Bill Fortune, of course, although I don't think I ever bought anything from him!!

Best car care tip to share: To get a tough Phillips screw out without rounding the head, dip the tip of the screwdriver in valve grind compound first. The grit will hold the screwdriver in place and prevent slipping.



Vintage Article

Page 32 • March/April • THE SETOFF

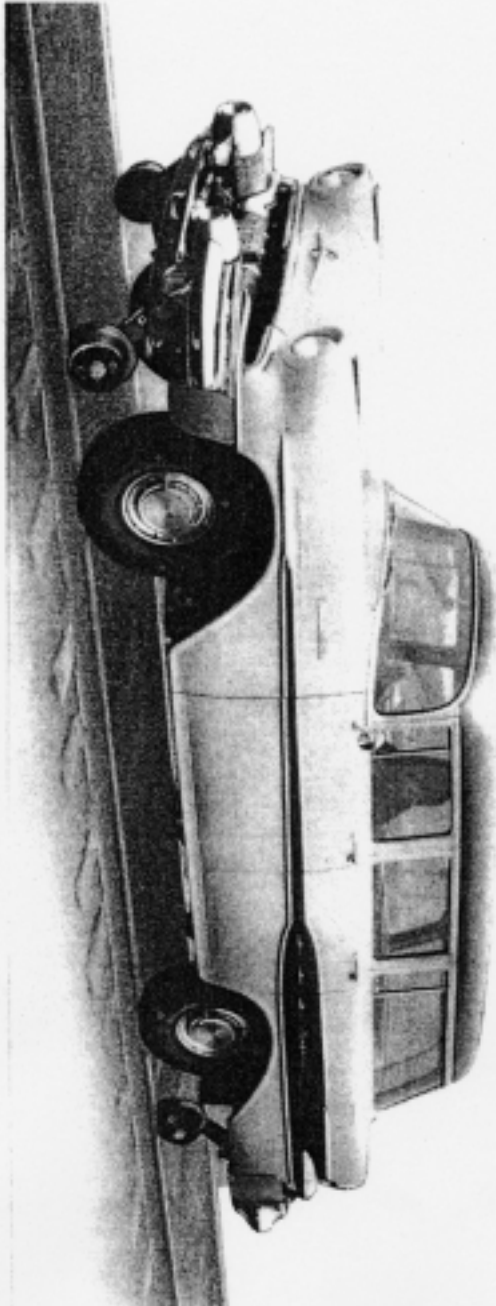

A34 SERIES B HY-RAIL CAR

For Time Saving Inspection Service

When using the A34, inspection trips can be made in comfort and in the shortest possible time. It is a very flexible unit that seats eight people, and can be changed from road to rail operation in a very few minutes. Guide wheels are raised and lowered hydraulically, and held in place by a separate mechanical lock. Fully equipped, has power brakes and steering, and power-dividing differential. Refer to bulletin 707 for complete details.

SPECIFICATIONS: ENGINE: Power V-8 1357 C.F.T. TRANSMISSION: Dual range Hydraulic. PNEUMATIC BRAES: 8.50 x 14.4 ply Nylon wheels. LOAD CAPACITY: Gross plus 1000 lbs.

ACCESSORIES: Air conditioning



From Fairmont's 1957 catalog.

Service Information

SECTION NO. 7

FISHER BODY SERVICE NEWS



BODY LUBRICATION

The movable mechanical hardware parts of a Fisher Body are lubricated at the factory to ensure proper and quiet operation. Because of the frequent use of some parts such as door locks and door lock strikers, it is important that the readily accessible parts be lubricated at least twice a year. Other body parts should be lubricated whenever access to the parts is available.

BODY PARTS WHICH SHOULD BE LUBRICATED TWICE A YEAR

INSTRUMENT PANEL COMPARTMENT DOOR HINGE

2562, 2562DF, 2563F, 2564DF

Apply one (1) or two (2) drops of dripless oil to male and female hinge straps at locations indicated at one (1) in illustration. Wipe off excess lubricant.

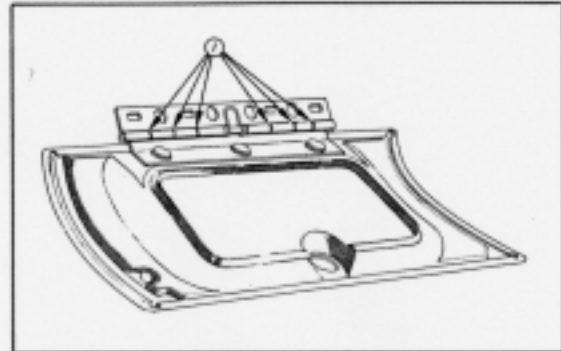
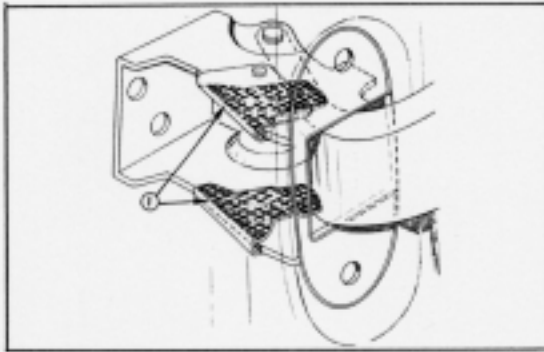

FRONT DOOR HINGE HOLD-OPEN CLIPS

2562, 2562DF, 2563F, 2564DF

Wipe off dirt and apply light coat of #630 AA Lubriplate or its equivalent to clips indicated at one (1) in illustration.

DOOR JAMB SWITCH

2562, 2562DF, 2563F, 2564DF

Apply light coat of #630 AA Lubriplate or its equivalent to surface of switch plunger indicated at one (1) in illustration.

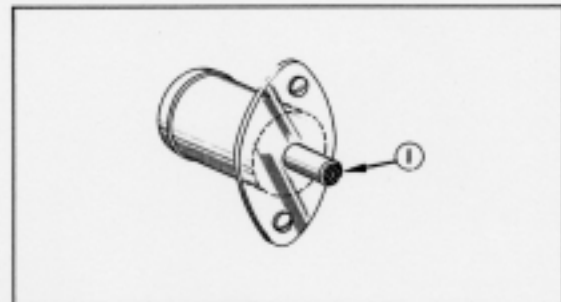
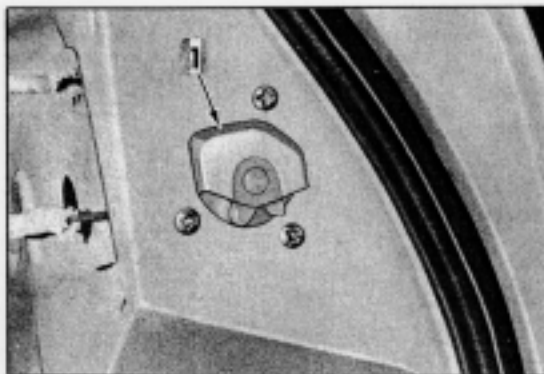

DOOR LOCK

2562, 2562DF, 2563F, 2564DF

Wipe off dirt and apply thin coat of stick type lubricant on surface of lock bolt housing indicated at one (1) in illustration. Wipe off excess lubricant.

DOOR LOCK STRIKER

2562, 2562DF, 2563F, 2564DF

Wipe off dirt and apply thin coat of stick type lubricant to top surface of striker teeth indicated at one (1) in illustration. After lubrication, close door several times and remove excess lubricant along side edge of teeth.

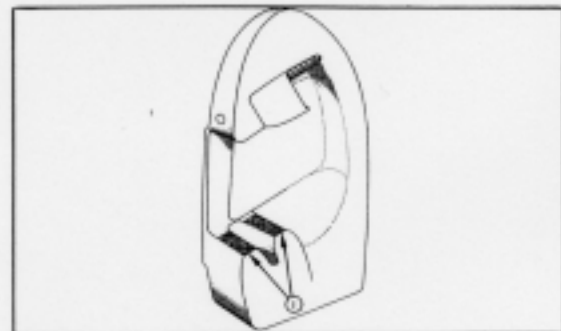

Service Information

Fisher

FISHER BODY SERVICE NEWS

Fisher

REAR DOOR HINGE AND HOLD-OPEN ASSEMBLY

2562, 2562DF

Wipe off dirt and apply one (1) or two (2) drops of mixture specified below to points indicated by arrows in illustration. Wipe off excess lubricant. Mixture is made up in a proportion of 1 lb. of #630 AA Lubriplate to 2 quarts of mineral spirits.

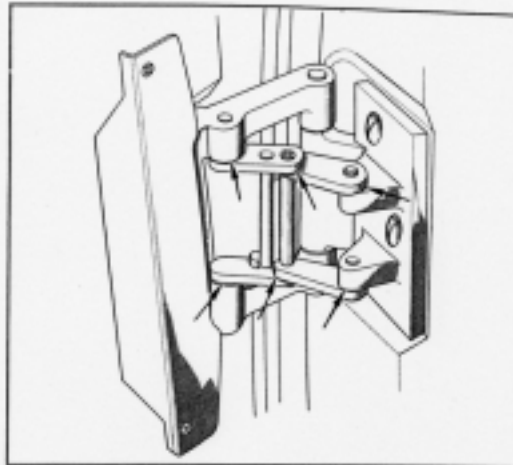
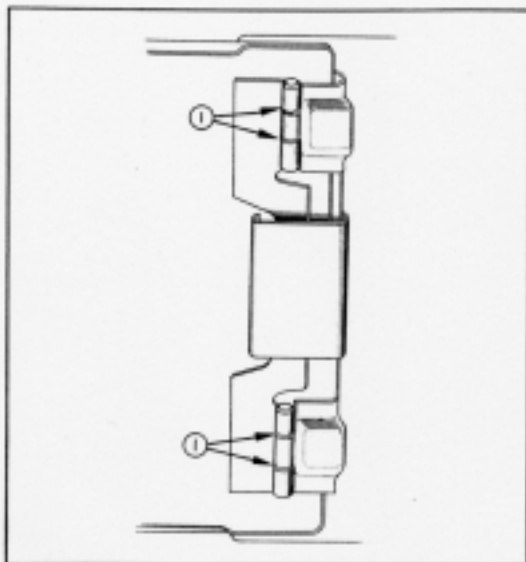

GAS TANK FILLER DOOR

2562, 2562DF, 2563F, 2564DF

Apply one (1) or two (2) drops of driptless oil to hinge points indicated at one (1) in illustration. Wipe off excess lubricant.

FRONT SEAT SIDE PANELS

2562, 2562DF, 2563F, 2564DF

Apply light coat of stick type lubricant along upper edge of front seat side panel indicated at one (1) in section "B-B". Wipe off excess lubricant.

The panel should be lubricated twice a year, or whenever an objectionable noise due to friction between side panel and leather seat trim is present.

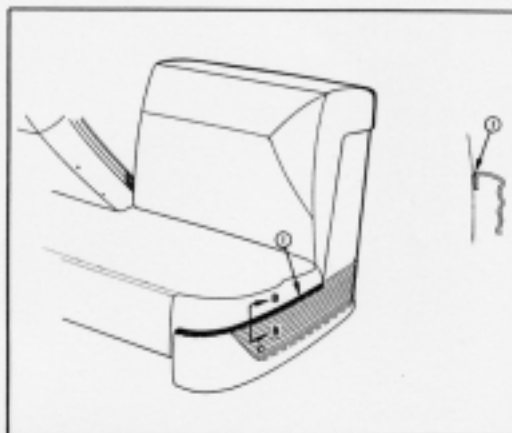
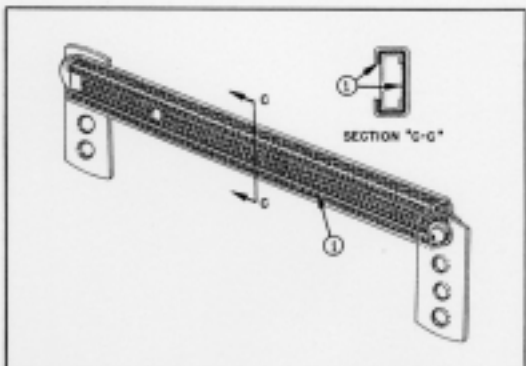

LIFT GATE SUPPORT ASSEMBLY

2562, 2562DF, 2563F, 2564DF

Wipe off dirt and apply #630 AA Lubriplate or its equivalent over inside surface of support outer channel indicated at one (1) in Section "C-C".

Service Information

Fisher

FISHER BODY SERVICE NEWS

Fisher

BODY PARTS WHICH SHOULD BE LUBRICATED WHEN ACCESS TO PARTS IS AVAILABLE

WINDSHIELD WIPER MOTOR AUXILIARY DRIVE AND WIPER TRANSMISSION

2562, 2562DF, 2563F, 2564DF

Apply #630 AA Lubriplate or its equivalent to locations indicated at one (1) in illustration.

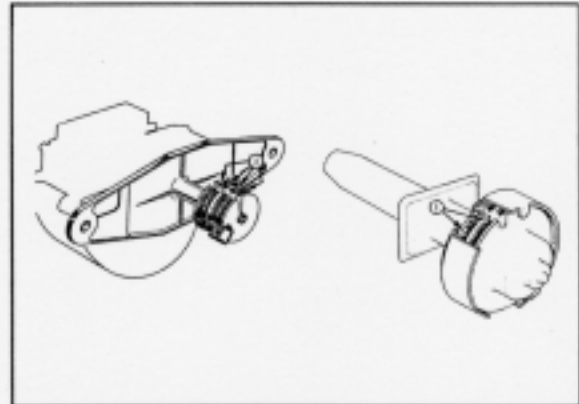

DOOR LOCK PARTS

1955 PONTIAC 2562, 2562DF, 2563F, 2564DF

Lubricate moving parts of door lock with lubricant mixture made up in proportion of 1 lb. of #630 AA Lubriplate to 2 quarts of mineral spirits.

DOOR AND REAR QUARTER WINDOW REGULATOR AND CAM CHANNELS

2562, 2562DF, 2563F, 2564DF

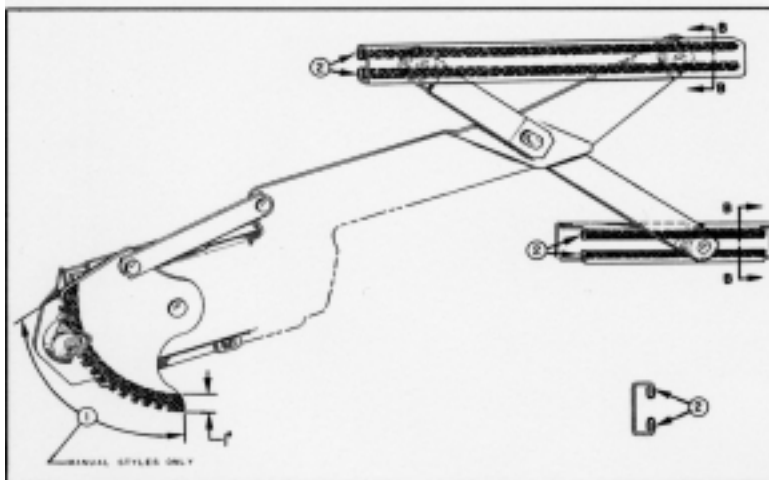

On manual regulators, apply coat of #630 AA Lubriplate or its equivalent to rack portion of regulator sector as indicated at one (1) in illustration. On all regulators, apply #630 AA Lubriplate or its equivalent to channel portion of cam as indicated at two (2).

LIFT GATE HINGE ASSEMBLY

2562, 2562DF, 2563F

Wipe off dirt and apply #630 AA Lubriplate or its equivalent to hinge areas indicated by arrows.

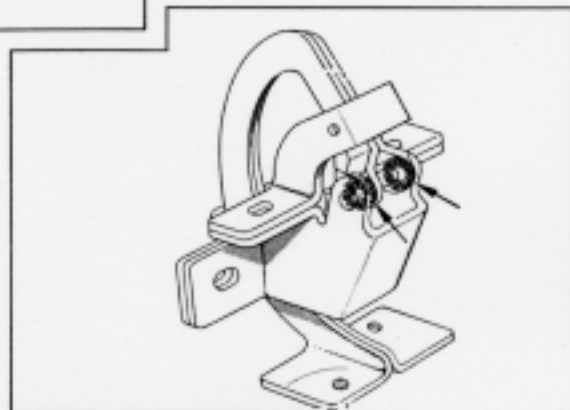

Upcoming Event

POCI WESTERN REGIONAL MEET CHIEFS ALONG THE CHANNEL

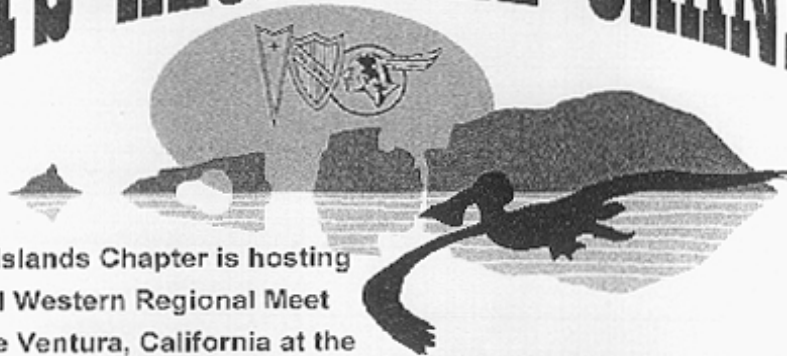

The Channel Islands Chapter is hosting the 2002 POCI Western Regional Meet in picturesque Ventura, California at the Clarion Hotel, Ventura Beach, September 27-29, 2002. Only steps away from our beautiful beaches and marinas. Downtown offers Historical sites and landmarks such as the Ventura Pier, San Buenaventura Mission and the Cross at Grant Park. We also offer antique shops, cafes, Ventura Harbor Village and many vistas.



Clarion Hotel, Ventura Beach
2055 East Harbor Blvd.
Ventura, CA 93003

Hotel Reservations
1(805) 643-6000
Special Rate
\$89.00(king) + tax
\$99.00(2/dbl) + tax

Special room rates apply for 3 days before, during and after event.

REGISTRATION FORM

LAST NAME _____ FIRST NAME _____
STREET ADDRESS _____
CITY _____ STATE _____ ZIP CODE _____
PHONE # _____ E-MAIL _____

Current POCI # _____ Required

Registration Fee: \$30.00 non refundable

Last day of entry September 6, 2002 - no late or day of show entries

You will receive a complete registration and activities package by return mail.

For swap meet and vendor space prices check box. Swap meet Vendor

Make checks payable to: Channel Islands Chapter, POCI

Mail to: Jan McGarry 5690 Aurora Dr., Ventura, CA 93003

Information: Dave McGarry (805) 654-0401 magoo2dave@aol.com or Jim Glaze (805) 486-0881 jaglaze@gte.net

Chapter Membership

First Name	Last Name	Address	City	State	Zip	Phone
Hershel	Beahm	1217 Spencer Ave	San Jose	CA	95125	408-297-9300
William	Bean	3914 N. 650 W.	Ogden	UT	81414	801-737-1212
Cary	Birenbaum	10260 N. Shannon Rd	Tucson	AZ	85742	602-742-2713
Jim & Sandra	Bowers	7924 S. State Rd 61	Monroe City	IN	47557	812-743-2949
Wheeler & Kathleen	Bradley	4 Barton Lane	Middletown	RI	02842	401-847-9053
Lou	Calasibetta	PO Box 1957	Stillwater	NJ	07875	973-383-2001
Harold & Carol	Cary	2315 19TH SW	Mason City	IA	50401	515-424-2663
Robin	Clark	668 E. 20th St	San Bernardino	CA	92404	909-886-8615
Nicholas	Coats	26821 Ruther St. Unit I	Santa Clarita	CA	91351	
Javier	De La Pena	2032 Reynolds	Laredo	TX	78043	956-727-3710
Ralph & Edie	DeNuzzio	8961 N Lake Dasha Dr	Plantation	FL	33324	954-969-5300
Dennis & Sonja	Doyle	6871 Colorado Ave	La Mesa	CA	91942	619-464-0438
Noel & Starr	Evans	10 Church Hill Rd	Washington Depot	CT	06794	860-868-7723
Donn & Mary	Fallenbuchel	P.O.Box 2476	Lake Havasu City	AZ	86405	520-855-5494
Greg & Liana	Fisher	429 E. Queen St	Pendleton	SC	29670	864-646-7372
Eric & Julie	Foehr	15 Standish Rd	New Milford	CT	06776	203-354-1871
Bill	Fortune	11 Lakeview Dr	Nitro	WV	25143	304-755-2429
Richard & Pamela	Gabrielson	5762 Bellflower	Newark	CA	94560	510-794-4334
Susan & Jim	Gestwicki	855 Blackbird Landing Rd	Townsend	DE	19734	302-653-8010
Ron & Frances	Goodhue	PO Box 13078	South Lake Tahoe	CA	96151	530-577-5522
Michael	Green	11 Amber Sky Dr	Rancho Palos Verdes	CA	90275	310-377-6900
Lloyd & Shirley	Hahn	6468 Highway 83	Condon	MT	59826	406-754-2228
John & Marilyn	Havens	45 48th Street SE	Kentwood	M	49548	616-531-1381
Ron & Regina	Huddy	171 Mill Street	Newton	NJ	07860	201-383-8318
Dale & Debbie	Johannaber	9701 Dino Dr	Elk Grove	CA	95624	916-686-2571
John & Gene	Johnson	2000 North Rice Rd	Ojai	CA	93023	805-646-7354
Ray & Heidi	Kirshner	6575 Salt Rd	Clarence	NY	14031	716-741-2995
Dave & Cindy	Keetch	154 El Camino Pequeno	El Cajon	CA	92019	619-442-4182
Bill & Patty	Kuster	147 Westgate Dr	Wheeling	WV	26003	304-243-9590
Mark & Lorene	Miller	1408 Mt. Tricia Ave	West Covina	CA	91791	626-917-7565
Luke & Kathleen	Miller	11933 Highway G	Caledonia	WI	53108	414-835-4767
Marvin	Morton	622 Avenue C	Redondo Beach	CA	90277	414-835-4767
Jonny	Nilsson	Strandvagen 25	S-287 72 Traryd	Sweden		46-433-62669
Gary & DeeAnn	Parker	63 Sandstone Drive	Spencerport	NY	14559	585-352-1293
Mark & Robin	Petry	2806 Scarlett Dr	Augusta	GA	30909	706-736-3392
Greg & Marjorie	Pettit	4654 Calle Norte	Newbury Park	CA	91320	805-480-0830
Ronn & Patricia	Pittman	1024 Raddant	Batavia	IL	60510	630-879-7393
Richard	Plastino	431 S. Sierra	San Bernardino	CA	92408	909-884-6980
Rich & Paige	Pye	436 LaDue Rd	Brockport	NY	14420	585-637-2720
Ron & Veronica	Revisky	3205 Sherrill Road	Minooka	IL	60447	815-467-2287
Chris	Rogers	1393 Story Rd	San Jose	CA	95122	408-295-6318
Ricky & Leanne	Smith	PO Box 123	Holcomb	IL	61043	815-393-3606
John & Joanne	Snelgrove	408 San Bernardino Ave	Newport Beach	CA	92663	949-642-7089
Dick	Stampalia	905 S. 200th St.	Demoinis	WA	98198	206-870-9676
Ed	Vassar	One Laurel St. #104	San Carlos	CA	94070	650-591-2204
Dennis	Vaughan	1155 NW 133rd St	North Miami	FL	33168	305-685-3139
Dennis & Sharen	Wagner	16 S. White Bear Ave	St. Paul	MN	55106	612-731-0061
David & Mary Jean	White	4 Wainwright Avenue	Plainville	CT	06062	860-747-5682
Jack & Jill	White	64 Castle Heights	Deep River	CT	06417	860-526-9748
Norm & Bird	White	PO Box 444	Minden	NV	89423	702-265-2257
Tom	Young	204 Acacia Lane	Newbury Park	CA	91320	805-375-1320
Barry	Zalesky	7535 Horrocks St.	Philadelphia	PA	19152	215-722-3717

Safari Search

Cars for Sale

None in this issue.

Parts for Sale

None in this issue

Services Offered

Appraisals by RONN

certified associate IAAA
autos - trucks - toys



RONN PITTMAN
1024 S. RADDANT RD.
BATAVIA, IL 60510-3398
(630) 879-7383
(630) 202-1956 cell

“Appraisals By Ronn” is located in Batavia, IL. The owner, chapter member Ronn Pittman keeps this business going by himself, providing appraisals of autos, trucks, and toy vehicles. He has been in business approximately 20 years, previously managing body shops at GM dealerships. Actually, he states that he is retired, but is continuing with the appraisal business.

Ronn and his wife Pat enjoy two children and one granddaughter. His hobbies include collecting and building scale model cars, plus collecting, showing and “cruising” with real cars. His favorite Pontiacs are the 1950 2-dr hardtop and the 1955 Custom Safari, which is why he owns one of each. Next time you’re in need of an appraisal on your vehicle, contact “Appraisals by Ronn”!

Wanted

1956 – 58 Safari Photos and Literature. Editor needs more photos and literature regarding the 1956 through 1958 Pontiac Safaris. Send copies or e-mail scanned items to Rich Pye.

1956 Safari, painted metal trim (3 pieces) on the floor in the cargo area, next to the wheel wells, and both stainless trim pieces, near the rear fold down door for same. Jack Lander, 2405 Calle Andalucia, Santa Barbara, Ca. 93109, 805-962-5766, Jack Lande @ aol.com

1957 Pontiac Custom Safair 2-door, #3 condition or better, must have P/S and prefer full power options. Have cash, will travel. Joe, email - 747400pilot@compuserve.com

To place a free ad to sell a car or parts or to place a want ad, send your request to Rich Pye. Your ad should be related to 1955-58 Pontiacs, and it is recommended to include photos (electronic or paper). Ads are also welcome, send a business card for Pontiac related items or services to Rich.

POCI Chapter #10

www.customsafari.org

The Custom Safari Chapter is an official international chapter of the Pontiac Oakland Club, International, Incorporated. The POCI headquarters address is: 2017 Manatee Avenue, West, Bradenton, Florida 34205

Annual Dues are \$18.00. Renewals are due January 1st of each year. New member dues are pro-rated quarterly from January 1st. Applicants must be a current member of POCI prior to joining the chapter. Send payment to Starr Evans.

The Safari News is a quarterly publication produced by the chapter. Volume 1, Number 1 was distributed in December of 1993. A limited number of back issues are available. Write for further information.

President: Robin Clark, 668 E20th, San Bernardino, CA 92404
Vice President: Bill Fortune, 11 Lakeview Drive, Nitro, WV 25143
Secretary/Treasurer: Starr Evans, 10 Church Hill Rd, Washington Depot, CT 06794
Editor: Rich Pye, 436 LaDue Rd, Brockport, NY 14420

Directors:
Eastern Region: Lou Calasibetta, Box 1957, Stillwater, NJ 078775
Central Region: Ronn Pittman, 1024 Raddant, Batavia, IL 60510
Western Region: Ed Vassar, 705 B Broadway, Fairfield, CA 94533

For chapter information: Write: 436 LaDue Rd, Brockport, NY 14420, Phone: (585) 637-2720, e-mail: rpye@rochester.rr.com



KILLS RUST
Authorized Dealer
CPR
431 S. Sierra Way
San Bernardino CA 92408
800-884-8888 FAX 904-7872



Give Your Car **CPR**
With Pleasure
CALIFORNIA PONTIAC RESTORATION
401 S. SIERRA WAY
SAN BERNARDINO, CALIFORNIA 92408
(909) 884-8888 FAX 909-884-7872



Scale Model Cars
RONN PITTMAN
HOLDER OF ONE OF THE WORLD'S LARGEST
SCALE MODEL CAR COLLECTIONS
BUILDER - COLLECTOR SINCE 1955
1024 S. Raddant Rd.
Batavia, IL 60510-0338 (830) 879-7383



PONTIAC *Exclusively*
With Express On The ... 16 - 72
Any Pontiac Old, New - Licensed - Scale Models
RONN PITTMAN
1024 S. Raddant Rd.
Batavia, IL 60510-0338 (830) 879-7383



Fremont Auto, Air, & Electric
Rich & Pave Gamble - Owners

37555 A Cottleville Place - Fremont, OH 43420 - (614) 763-2340