

Spring 2003
Volume 5, Number 1

Custom Safari Chapter

Fun Safari Gathering in Southern California



Rockin Robin with
'57 Safari - August, 2000

It was bound to happen! One warm August day, chapter President Robin Clark and Tom Young got together at Tom's home in Southern California for a Safari Pow Wow. They were joined by Marvin Morton and Mike Green who brought their '57 Safari wagons. With three Safaris all in one place, everyone couldn't help but to have a good time.

Look inside for more to this story.

From the President's Garage

By Robin Clark

Greetings everyone,

Time to head 'em out and move 'em on up to St. Louis for our annual P.O.C.I. Convention; not to mention, our annual Custom Safari chapter meeting. So, it's time to get those Safari's out of the barn, washed, waxed, and ready for the big show. Hopefully we can have a big turnout this year, being in the central location that it is.

I'm going to be able to make it this year, although I will be flying. It will be good to see some friends, and hopefully make some new ones. We have our annual chapter meeting scheduled, so bring your ideas and thoughts about the chapter with you. We also have a breakfast cruise scheduled, you can bring your appetites to that one. On show day we will have our chapter peer voting for Best Safari. We will discuss that award and what time to meet at our annual meeting. Looking at the schedule of things to do, sounds like it will be a good time.

I'd like to take time to thank Tom Young for his article in the last issue of the Safari news. I've seen his car, and it truly does have everything you can think of, although Tom did forget to mention the kitchen sink in the trunk. I'm sure some of us have other cars other than Safari's in the barn, so why not tell us about them. Now, of course the Safari is your No. 1 classic, but I'm sure some of us would like to hear about the others in your fleet.

There is nothing new from me on the Safari front. I do have a major personal item that has come up..... Retirement. Life is definitely better now. I now have some serious Safari time coming up. So, that's all for now. I've got to get out to the garage .

See you in St. Louis,



Robin



Behind the Wheel in the Editor's Seat

By Rich Pye

Hello Everyone!

Another season has past by, (they seem to be moving faster as I get older), and car cruising season is upon us. If you haven't got your car on the road yet, drop this newsletter right now and get out there and do it!

In this issue is another story from Tom Young regarding a Pow-Wow at his house awhile back with some Custom Safari members. Thanks again Tom for your support of the newsletter! Check out Safari Member of the Quarter John Snelgrove and his '57 Custom Safari. Thanks also to Gary Parker for his contributions of the Service Craftsman News Flash's from 1955.

Please look at the update regarding the Custom Safari Chapter events and times at the convention. There are some unannounced things we are doing that aren't in the convention handouts. I look forward to seeing many of you there, especially our newer members and those that haven't traveled to a convention in awhile. Speaking of infrequent convention attendees, it will be good to see our President, Robin Clark, at the convention. It will also be a relief to have someone else run the chapter meeting for a change! Oh sorry Robin, I forgot to tell you that earlier. I can now sit back and ask the questions for a change. Actually Starr ran the meeting last year, so she and I can now sit back and enjoy the meeting!

The customsafari.org website has been updated a little bit over the last few months. The latest Safari News, parts for sale, member information, and other pertinent information are all up to date. I only need to add more member car photos to the Flash demo that runs with the Beach Boys song to bring totally up to date. If you have other suggestions or more photos of your car(s), please pass them on to me. Also any updates to the "For Sale" stuff, let me know.

An issue regarding the member roster came up over the last few months, which caused me to have to restrict the amount of personal information that was posted in the past. Member names are the only thing found now on the web. Contact information will only be found in our newsletters going forward. A few members noticed that their personal information was easily found using a search engine such as Google. Google "bots" and "spiders" crawl the web on a regular basis and can store (cache) information regarding web sites. In our case you could enter a phone number into Google and bring up a link and part of the file with personal information. For those with unlisted phone numbers, this was a problem. For those with listed phone numbers, there are many sites that provide this type of look-up. In any case I have put in the proper meta-tags to prevent Google and other search engines from "spidering" and "cacheing" the site.



Anyhow, enough on the computer technical stuff. I've got to get this issue mailed out and get ready for the convention. Hope to see many of you there with your cars.

Rich

Safari Member of the Quarter

Your Name: John Snelgrove

Spouse's name: Joanne

Child(ren)'s name(s) and age(s): Andrew (26), Elizabeth (22), Joseph (20), MaryEllen (16)

Safari(s) Owned: 1957 Custom Safari

When/Where did you acquire your first Safari? I bought the '57 Safari 4 years ago in Northern California.

What was your first car? A 1955 Pontiac 4 door station wagon. It was a great surf wagon I bought in 1960.

What was your first Pontiac? The '55 wagon

Reason for "collecting" Safaris: Fell in love with the '57 Custom Safari back in the early '60's.

Reason for joining the Custom Safari Chapter: To meet other owners

Favorite Safari Accessory owned: Wonder Bar Radio with Power Antenna

Most wanted Safari Accessory: Air Conditioning

Do you have "other" Pontiacs? If so, list model and year: No

What are your favorite non-Pontiac hobbies? Surfing. Even after 40 years of doing it.

Least favorite car task: Block sanding in preparation for painting.

Most favorite car task: Putting the car together

Best thing about being a Pontiac Custom Safari Owner: The looks the car gets.

Favorite non-Safari car: My other car, a 1948 Mercury Woody.

Favorite car-related web site: None

Favorite parts vendor: Any that have what I need. I've had good luck with CPR in San Bernardino, CA..

Best car care tip to share: Drive them as often as you can.

*John Snelgrove's 1957 Custom Safari
Charcoal Gray & Silver Beige*



Chapter Membership

First Name	Last Name	Address	City	State	Zip	Phone
William	Bean	3914 N. 650 W.	Ogden	UT	81414	801-737-1212
Jim & Sandra	Bowers	7924 S. State Rd 61	Monroe City	IN	47557	812-743-2949
Lou	Calasibetta	PO Box 1957	Stillwater	NJ	07875	973-383-2001
Harold & Carol	Cary	2315 19TH SW	Mason City	IA	50401	515-424-2663
Robin	Clark	668 E. 20th St	San Bernardino	CA	92404	909-886-8615
Javier	De La Pena	2032 Reynolds	Laredo	TX	78043	956-727-3710
Ralph & Edie	Denuzzio	8961 N Lake Dasha Dr	Plantation	FL	33324	954-969-5300
Sally	Dubravetz	2176 Mingo Trail	Akron	OH	44312	330-784-7319
Noel & Starr	Evans	10 Church Hill Rd	Washington Depot	CT	06794	860-868-7723
Donn & Mary	Fallenbuchel	P.O.Box 2476	Lake Havasu City	AZ	86405	520-855-5494
Greg & Liana	Fisher	429 E. Queen Street	Pendleton	SC	29670	864-646-7372
Eric & Julie	Foehr	15 Standish Rd	New Milford	CT	06776	203-354-1871
Bill	Fortune	11 Lakeview Dr	Nitro	WV	25143	304-755-2429
Richard & Pamela	Gabrielson	5762 Bellflower	Newark	CA	94560	510-794-4334
Susan & Jim	Gestwicki	855 Blackbird Landing Rd	Townsend	DE	19734	302-653-8010
Ron & Frances	Goodhue	PO Box 13078	South Lake Tahoe	CA	96151	530-577-5522
Larry & Julia	Gorden	12501 East Avenue H	Lancaster	CA	93535	661-946-1646
Michael	Green	11 Amber Sky Dr	Rancho Palos Verdes	CA	90275	310-377-6900
Al	Grider	1605 Starnes Loop Rd	Grant	AL	35747	256-728-2703
Lloyd & Shirley	Hahn	6468 Highway 83	Condon	MT	59826	406-754-2228
William & Oda	Hanners	15168 Sam Snead Lane	Ft. Myers	FL	33917	239-543-3510
John & Marilyn	Havens	45 48th Street SE	Kentwood	MI	49548	616-531-1381
Ron & Regina	Huddy	171 Mill Street	Newton	NJ	07860	201-383-8318
John & Gene	Johnson	2000 North Rice Rd	Ojai	CA	93023	805-646-7354
Randy & Robin	Kerdoon	22287 Mulholland Hwy #383	Calabasas	CA	91302	818-225-1116
Ken & Kathy	Machowski	82 Union Turnpike	Branchville	NJ	07826	973-948-6556
Luke & Kathleen	Miller	11933 Highway G	Caledonia	WI	53108	414-835-4767
Mark & Lorene	Miller	1408 Mt. Tricia Ave	West Covina	CA	91791	626-917-7565
Marvin	Morton	622 Avenue C	Redondo Beach	CA	90277	414-835-4767
Michael & Suzanne	Nible	PO Box 496	Black Diamond	WA	98010	360-886-2089
Jonny	Nilsson	Strandvagen 25	S-287 72 Traryd	Sweden		46-433-62669
Gary & DeeAnn	Parker	63 Sandstone Drive	Spencerport	NY	14559	585-352-1293
Mark & Robin	Petry	2806 Scarlett Dr	Augusta	GA	30909	706-736-3392
Ronn & Patricia	Pittman	1024 Raddant	Batavia	IL	60510	630-879-7393
Zach	Platt	6158 2nd Ave. South	St. Petersburg	FL	33707	727-344-2992
Ray	Pose	54 Harrison St.	Staten Island	NY	10304	718-981-7801
Rich & Paige	Pye	436 LaDue Rd	Brockport	NY	14420	585-637-2720
Chris	Rogers	1393 Story Rd	San Jose	CA	95122	408-295-6318
John & Joanne	Snelgrove	408 San Bernardino Ave	Newport Beach	CA	92663	949-642-7089
Dick	Stampalia	905 S. 200th St.	Demoinis	WA	98198	206-870-9676
Ed	Vassar	PO Box 171	Dunnigan	CA	95937	530-724-0154
Dennis & Sharen	Wagner	16 S. White Bear Ave	St. Paul	MN	55106	612-731-0061
David & Mary Jean	White	4 Wainwright Avenue	Plainville	CT	06062	860-747-5682
Jack & Jill	White	64 Castle Heights	Deep River	CT	06417	860-526-9748
Norm & Bird	White	PO Box 444	Minden	NV	89423	702-265-2257
Tom	Young	204 Acacia Lane	Newbury Park	CA	91320	805-375-1320
Barry	Zalesky	7535 Horrocks St.	Philadelphia	PA	19152	215-722-3717

Safari Search

Cars for Sale

None in this issue.

Parts for Sale

See Donn Fallenbuchel's list of '57 Safari Parts on the back inside cover

Wanted



Restoration Project **HELP WANTED**

Recently disabled Southern California
(Ventura County) club member/enthusiast
is seeking assembly help on my

1957 CUSTOM SAFARI

Need a part-time hobby related job?

*I can pay flat rate per task or hourly is OK too.
I need someone with experience on 1957 details.*

CALL OR E-MAIL FOR SPECIFIC INFORMATION

John @ (805) 646-7354

email: tvdesign@prodigy.net

1956 – 58 Safari Photos and Literature. Editor needs more photos and literature regarding the 1956 through 1958 Pontiac Safaris. Send copies or e-mail scanned items to Rich Pye.

1956 Safari, painted metal trim (3 pieces) on the floor in the cargo area, next to the wheel wells, and both stainless trim pieces, near the rear fold down door for same. Jack Lander, 2405 Calle Andalucia, Santa Barbara, Ca. 93109, 805-962-5766, Jack Lande @ aol.com

1957 Pontiac Custom Safair 2-door, #3 condition or better, must have P/S and prefer full power options. Have cash, will travel. Joe, email - 747400pilot@compuserve.com

To place a free ad to sell a car or parts or to place a want ad, send your request to Rich Pye. Your ad should be related to 1955-58 Pontiacs, and it is recommended to include photos (electronic or paper). Ads are also welcome, send a business card for Pontiac related items or services to Rich.

Feature Story

Safari Pow-Wow Southern California Style!



Who said you're too old to have a tail-gate party? Not if you live in Southern California!

Great weather, understanding neighbors, good food and lots of Pontiac parts proved to be a great combination for a few Pontiac Safari owners to gather at Tom Young's home one fine summer day.

Chapter President Robin Clark spearheaded the recruitment effort to lure Mike Green of Rancho Palo Verdes, CA and Marvin Morton of Redondo Beach, CA into the Custom Safari Chapter by meeting, eating and having some fun. Did they have fun? You bet!

The fun started on the local highways. Mike and Marvin merged into a small convoy while Robin was only minutes behind. Seeing three Safari wagons on the freeways of Southern California is a rare event. Finding Tom's house was easy - all you had to do is look for a lot of old cars. Parking was at a premium but Safari wagons got first priority. After the introductions, everyone immediately started comparing each other's cars. It's not often that Safari wagons group together so there was plenty of excitement learning about each other's cars. After nearly an hour of Safari talk, the group went indoors where Tom had a special surprise awaiting. Tom had set-up a unique display of 1957 Pontiac literature and memorabilia including a lighted paint-selector, posters, dealer albums, training records, and more. Hardly anybody had ever seen most of the memorabilia displayed.

Everyone had brought photos of other Safari wagons that they had seen during their adventures to purchase the right Safari wagon. Just about the time the photo sharing was done, it was time to enjoy a home barbecue lunch. On the menu was hamburgers, hot dogs, salads and fresh fruit. The food was great and very filling.



Top: From left to right; Mike Green, Marvin Morton and Robin Clark holding a tail-gate meeting in Tom Young's driveway. Neighbors could not help but stare at the sudden invasion of Safari wagons.

Left: Robin Clark demonstrates his superior mechanical skills as he installs a knob for the heater temperature control on Mike Green's Safari. According to the speedometer, Robin was doing the repair job while traveling at over 125 mph! Fortunately, Mike was able to find a good working speedometer during Tom's swap meet.



Above: Tom's Garage Swap Meet. Everyone enjoyed searching through many boxes of Pontiac parts. Mike Green found a few valuable parts to help complete his Safari wagon.



Above: Marvin with his very original '57 Safari wagon. The Silver Beige and Charcoal Gray paint was shiny and bright. But his tail gate fell victim to a local bird who left excrement right at the spot where Marvin placed his hand!

Below: Mike with his prized '57 Safari. He purchased the car with a few parts missing so Mike keeps himself busy on weekends restoring his car.



Once the talking, photo sharing and dining was done, everyone gathered in Tom's garage to search through many boxes containing 1955-58 Pontiac parts. Two boxes contained nothing but Safari parts including very hard to find trim pieces. After more than 1 hour of searching, everyone was satisfied with their newly found treasures. For Mike Green, some parts were immediately placed on his vehicle.

It's always interesting to compare body production numbers, paint and accessory codes which are accessible from the firewall tag.

Robin's Safari:	CL 774	Body #
	245	Trim
	PRN	Paint
	BKI	Accessories
Mike's Safari:	CL 1119	Body #
	245	Trim
	PPN	Paint
	BKG	Accessories
Marvin's Safari:	CL 1260	Body #
	244	Trim
	QQH	Paint
	BKII	Accessories

Robin's tag is a bit unusual. The paint code indicates PRN. The letter R is what makes the code very odd. According to Pontiac color guides, PPN is the correct "Starlight" Two Tone color for the car - Kenya Ivory lower body with Cordova Red insert & roof. PRN would indicate an Ivory lower with a Carib Coral insert and Red roof. Robin may have to do a bit of paint stripping to determine whether or not the code is in error or that he really has a odd colored Safari. Start sanding Robin!

Everyone enjoyed the gathering so much that plans are in the making for another meeting in early spring. By that time, Robin should have the answer about the paint code!

Below: Robin Clark caught in the act of adjusting his Safari's loose & rusty fender for the pending photo shoot!



Vintage Photos



2003 Convention Update



Custom Safari Chapter Events at the Convention:

Wednesday July 9th, 8:00 AM ==> Breakfast Cruise to the Cracker Barrel within a 10 mile radius of the convention site.

Thursday July 10th, 11:00 AM to 12:00 PM ==> Annual Chapter Meeting at convention site.

Saturday July 12th, 12:00 PM ==> Custom Safari Chapter Voting

Service Information



No. 55-3

January 24, 1955

ATTENTION: DEALER SERVICE MANAGER

INSTALLATION OF AIR CLEANER ON FOUR-BARREL CARBURETOR

When installing the air cleaner on cars equipped with the four-barrel carburetor, always tighten the top wing nut with the cleaner top cover centered over cleaner oil reservoir before attaching the silencer brace. This prevents improper seating of the cleaner top cover and the resultant air leak which causes noisy operation.

When the cleaner top cover is removed for service, care should be taken to prevent damage to the lip which contacts the cleaner oil reservoir. Damage in this area will also result in an air leak.

CARBURETOR FLOODING

In the January issue of the Service Craftsman News it was stated that the fuel pump should be replaced if it was delivering in excess of 5 pounds pressure. A study of this condition shows that high pressure may be encountered due to the fuel pump diaphragm being installed with insufficient slack. The corrective procedure to be followed when high fuel pump pressure is encountered on a new car is listed below. If this does not reduce the pressure below 5 pounds, the pump should be replaced.

1. Remove pump from engine and place mounting flange in a vise with fuel side up.
2. Loosen cover screws two turns to relieve diaphragm.
3. With a short section of pipe fitted over rocker arm, move arm up and down several times.
4. Press rocker arm up and hold in that position while tightening all cover screws.
5. Reinstall pump.

Engineering tests have shown that many cases of Carter carburetor flooding can be corrected by removing the strainer nut (two on four-barrel) and using air pressure to blow out any dirt particles that may have accumulated under the float needle. **CAUTION: DIRECTING FULL AIR PRESSURE INTO BOWL MAY COLLAPSE FLOATS.**

ROUGH ENGINE IDLE AND HIGH VACUUM WHISTLE

Several reports have been received on rough engine idle and/or a whistling sound under high vacuum conditions, such as closed throttle coasting. Investigation shows that these were due to loose intake manifold bolts and nuts. In all cases of the above condition, tighten intake manifold bolts and nuts to 40-45 lb. ft. torque before further investigation.

Service Information



No. 55-20

May 27, 1955

ATTENTION: DEALER SERVICE MANAGER

CORROSION OF TERMINALS WITH RESULTING SHORT CIRCUIT - PARKING AND SIGNAL LAMPS

For a short period, parking and signal lamp assemblies were used which may become corroded in the socket areas and result in a short circuit. As soon as this condition was discovered, changes were made to eliminate the entrance of moisture.

This is to advise that in cases where a short circuit occurs, and there is evidence of moisture having been in the socket or on the reflector below the socket, that the lamp body and wire assembly should be replaced with a new one. These parts, 5945817 L.H. and 5945818 R.H., are listed in Group 2, 899. Flat rate operation 12-340 applies on the replacement of the body assembly.

Inspection for evidence of moisture can also be made visually through the lens at any time when a car is in for service or when a bulb is being replaced. In all cases where evidence of moisture is found, the lamp body and wire assembly should be replaced.

TIRE INFLATION - SAFARI STATION WAGON

The tire inflation chart given on page 21 in the Owner's Guide will be changed in the next printing to indicate that tire inflation pressure recommendation for the "Safari" is 24 lbs. front and rear, cold. While these are equipped with 7.60-15 4-ply rating tires, it has been found more desirable to use the 24 lb. pressure than the 26 lb. given in the owner's guide. Start using the new recommendation at once.

NOISY OIL PRESSURE GAUGE

A buzzing noise which comes from the oil pressure gauge, or the line from the engine to the gauge, can be corrected by disconnecting the line at both ends and blowing air into the gauge end to remove oil from the line. When the line is reconnected it should be tightened securely at both ends before the engine is started.

Service Information



No. 55-22

June 23, 1955

ATTENTION: DEALER SERVICE MANAGER

BODY TO FRAME INTERFERENCE

The following body and frame interference points have been found as contributing factors in the amplification of road, body and differential noises. These points should be carefully checked before further diagnosis or corrective action is undertaken.

- A. Possible interference at the pinch weld of the rear quarter and rear deck floor to the rear bumper face bar supports and frame at kickups.
- B. Insert an insulating pad between the rear deck floor and fuel tank. (See page 78, June Service Craftsman News.)
- C. Possible contact of fuel line near left rear spring front hanger to both frame and floor pan.
- D. Possible interference at rivet that secures the left rear spring front hanger to both frame and floor pan.
- E. The right side lower engine splash apron contacting #2 crossmember.
- F. Possible flexing of the right side toe board.
- G. Remove #4 or #5 inner body bolt (whichever is applicable to individual body styles) from early production cars. Reference - Pontiac Service Craftsman News, May, 1955 - page 56.

CARBURETOR PUMP ROD ADJUSTMENT CORRECTION

Under "Pump Rod Adjustment" page 72 of the June Service News, the distance from the top of the air horn casting to the BOTTOM of the pump rod should be 1-1/16". This specification is listed incorrectly as from the air horn casting to the top of the pump rod. The same correction should be made on page 74 under "Adjustment Specifications".

AIR CLEANER STUD - CARTER FOUR BARREL CARBURETOR

If the air cleaner to carburetor stud pulls out of the carburetor body, it is usually caused by the stud not being threaded deep enough into the body. It is not always necessary to replace the carburetor body in such a case. The threads in the body should be cleaned up by using a 1/4"-20 thread tap. If necessary, also clean the threads on the stud using a 1/4"-20 thread die. All metal chips should be thoroughly removed before reassembly.

Service Information



No. 55-28

October 3, 1955

ATTENTION: DEALER SERVICE MANAGER

RATTLES IN LIFT GATE IN OPEN (HORIZONTAL) POSITION 1955 Pontiac 2564DF "Safari"

If rattles in the lift gate supports are encountered when a station wagon is driven with the lift gate in the open (horizontal) position, the supports may be reworked to eliminate excessive movement of the lift gate as follows:

1. Remove right lift gate support.
2. At a distance $3/16$ " above the original slot in the support used for locking the lift gate in the open (horizontal) position, make an additional slot of the same size. See Fig. 1. The use of this new slot in the right lift gate support when locking the lift gate in the horizontal position will eliminate any looseness between the inner and outer channels of the supports. Slot can be made as follows:
 - a. At required location on outer channel, drill pilot hole and file support to obtain required slot size.
 - b. Clean off metal particles which result from drilling and filing operations.
 - c. Relubricate channel as required.

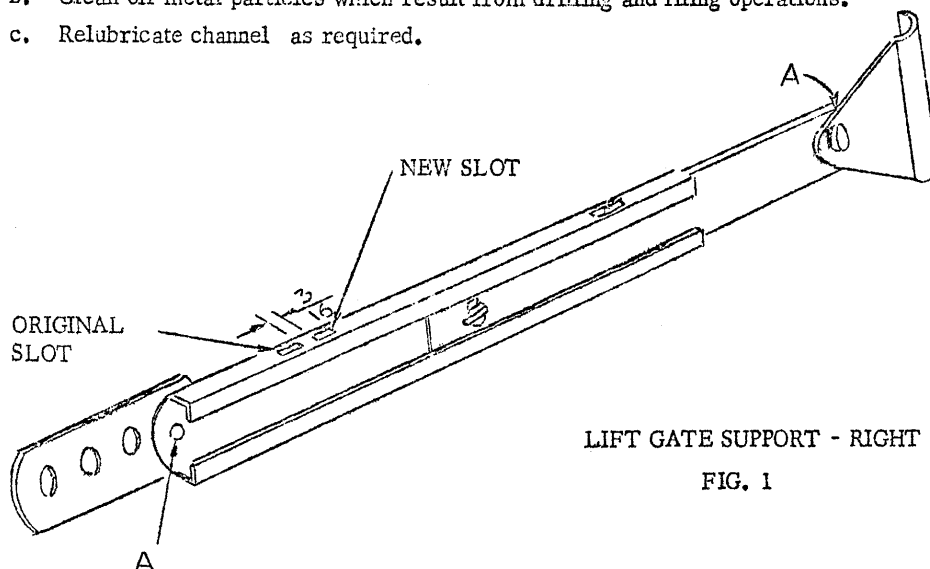

3. Peen the support rivets "A" to remove excess play between the support channels and their attaching brackets.
4. Reinstall right lift gate support.
5. Remove left lift gate support, peen around the support rivets and reinstall support.
6. Notify owner to use the new locking slot when driving the car with the lift gate in the open (horizontal) position.
7. The lift gate is not designed to be set in the full open position when car is being driven.

Donn Fallenbuchel's Parts Page

All Parts for 1957 Pontiac Safari

Donn has been encouraged to make room in the garage, so he has some parts for sale. No prices are listed, but he is selling them for fair offers plus shipping. Please contact Donn at 520-855-5494 any time after 12:00pm, if you have questions.

*Radiator – Needs boil out
(2) Complete 3.90 Rear Ends
Power Steering Pump and Brackets
(2) Steering Columns
Front Brake Drums
(4) Chrome Rims (near new) 5x5
Heater and miscellaneous tin
Generator and Brackets
(2) Floor Mount Radio Speakers
Power Supply for Wonderbar Radio (only)
(1) – 4 BBL Manifold and Carburetor for 347 engine
58-60 Tri-Power Complete
Radio Delete Dash Fascia
Power Brake Booster and Pedal
Dual Exhaust Manifolds and Elbows
347 Chrome Valve Covers – Used*

plus other parts.....just ask.

*Wanted: Stainless Spear, front of gas door
 Trim under the tail lights*



Donn's Safari in progress. Not for Sale!!

POCI Chapter #10

www.customsafari.org

The Custom Safari Chapter is an official international chapter of the Pontiac Oakland Club, International, Incorporated. The POCI headquarters address is: 2017 Manatee Avenue, West, Bradenton, Florida 34205

Annual Dues are \$18.00. Renewals are due January 1st of each year. New member dues are prorated quarterly from January 1st. Applicants must be a current member of POCI prior to joining the chapter. Send payment to Starr Evans.

The Safari News is a quarterly publication produced by the chapter. Volume 1, Number 1 was distributed in December of 1993. A limited number of back issues are available. Write for further information.

President: Robin Clark, 668 E20th, San Bernardino, CA 92404
Vice President: Bill Fortune, 11 Lakeview Drive, Nitro, WV 25143
Secretary/Treasurer: Starr Evans, 10 Church Hill Rd, Washington Depot, CT 06794
Editor: Rich Pye, 436 LaDue Rd, Brockport, NY 14420

Directors:
Eastern Region: Lou Calasibetta, Box 1957, Stillwater, NJ 078775
Central Region: Ronn Pittman, 1024 Raddant, Batavia, IL 60510
Western Region: Ed Vassar, PO Box 171, Dunnigan, CA 95937

For chapter information: Write: 436 LaDue Rd, Brockport, NY 14420, Phone: (585) 637-2720, e-mail: rpye@rochester.rr.com



Scale Model Cars
RONN PITTMAN
HOLDER OF ONE OF THE WORLD'S LARGEST
SCALE MODEL CAR COLLECTIONS
BUILDER - COLLECTOR SINCE 1985
1024 S. RADDANT RD.
BATAVIA, IL 60510-3398 (630) 879-7393



PONTIAC Fremont
WITH EMPHASIS ON THE... '49 - '72
AND PROMOTIONAL ITEMS - LITERATURE - SCALE MODELS
RONN PITTMAN
1024 S. RADDANT RD.
BATAVIA, IL 60510-3398 (630) 879-7393



Appraisals by RONN
certified associate IAAA
auto - trucks - toys
RONN PITTMAN
1024 S. RADDANT RD.
BATAVIA, IL 60510-3398
(630) 879-7393
(630) 202-1956 cell

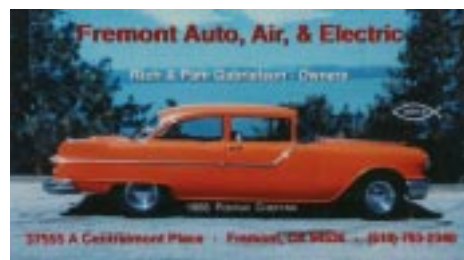

Fremont Auto, Air, & Electric
Rent & Buy Cars - Trucks - Owners
3155 A Centerville Place - Fremont, DE 19840 - (302) 353-2940